



# FIRESTOP CENTRE

Authorised New Zealand Distributor  
Ph (09) 483 4000 www.firestopcentre.co.nz

## AGNI-Wrap in a Hebel Wall (min 75mm) Pair Coil (PE or FR) with Cable and Pipe Max FRR -/120/120

System ID# FC833

### Step-by-step installation instructions:

1. Ensure the aperture is free from dust and debris.
2. Insert one revolution of AGNI-Wrap 50 into the annular gap each side of the wall leaving approx 12mm protruding outside the Hebel panel.
3. Apply AGNI-Black between AGNI-Wrap 50 and the pipe, finishing flush with the protruding AGNI-Wrap 50.
4. Apply 12mm x 12mm AGNI-Black fillet/cone between AGNI-Wrap and the wall.

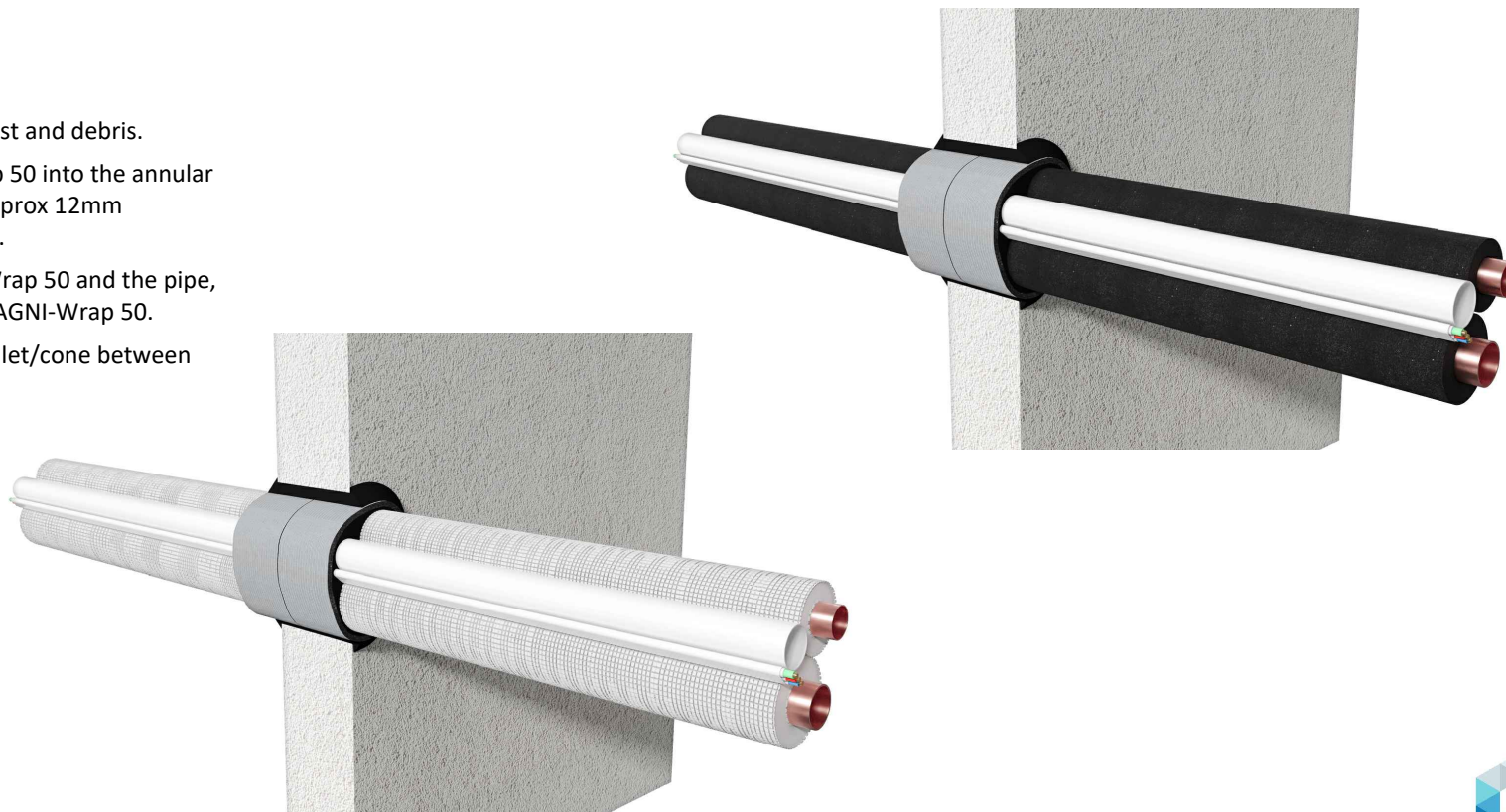

### Technical Information

|                         |  |
|-------------------------|--|
| Substrate               | Min. 75mm Hebel Wall                               |
| Service range           | PE/FR Pair Coil + TPS Cable + 20mm Condensate Pipe |
| Annular gap             | FR - 9.4 - 42.6mm<br>PE - 5.9 - 36.4mm             |
| AGNI-Products           | AGNI-Wrap 50, AGNI-Black                           |
| Protection installation | From both sides of the wall                        |

### Compliance Information

|           |                              |
|-----------|------------------------------|
| Standards | AS1530.4-2014, AS4072.1-2005 |
| FRR/FRL   | FR -/120/120<br>PE -/120/60  |
| Reference | PF24145                      |



**Agnitek**<sup>®</sup>  
FIRE RATED TECHNOLOGY

8 Clare St Bayswater  
VIC 3153, AUSTRALIA  
www.agnitek.com.au

#### Disclaimer

Agnitek reserves the right to modify product specifications without prior notice due to its ongoing research, development & certification programme. The information in this document is provided in good faith and is intended for guidance purposes only. Any accompanying drawings are solely for illustrative purposes. Since Agnitek cannot oversee installation methods or ensure site conditions, no warranties, expressed or implied, are intended regarding the products' actual performance. We do not accept liability for any loss, damage, or injury from using this information. Please take a look at the test reports displayed on a relevant AGNI-System webpage for all compliance specifics.

|      |            |
|------|------------|
| Date | 07.03.2025 |
|------|------------|



# FIRESTOP CENTRE

Authorised New Zealand Distributor  
Ph (09) 483 4000 www.firestopcentre.co.nz

## AGNI-Wrap in a Hebel Wall (min 75mm) Pair Coil (PE or FR) with Cable and Pipe Max FRR -/120/120

System ID# FC833

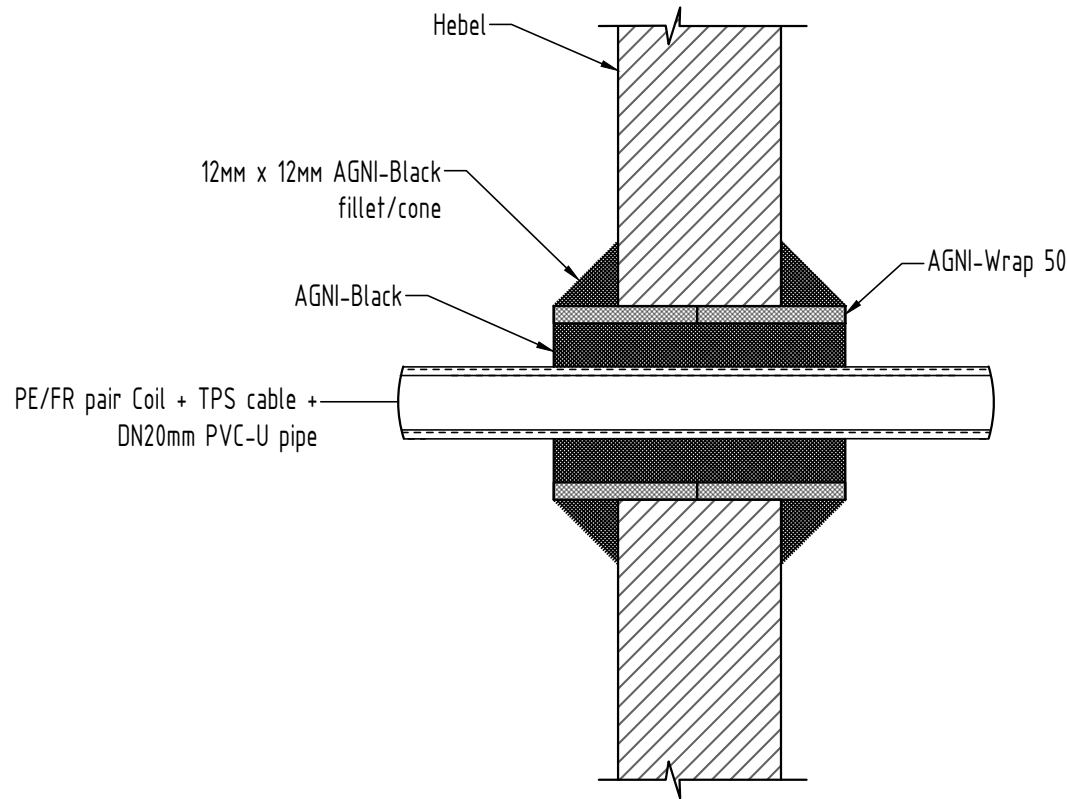

### Technical Information

|                         |  |
|-------------------------|--|
| Substrate               | Min. 75mm Hebel Wall                               |
| Service range           | PE/FR Pair Coil + TPS Cable + 20mm Condensate Pipe |
| Annular gap             | FR - 9.4 - 42.6mm<br>PE - 5.9 - 36.4mm             |
| AGNI-Products           | AGNI-Wrap 50, AGNI-Black                           |
| Protection installation | From both sides of the wall                        |

### Compliance Information

|           |                              |
|-----------|------------------------------|
| Standards | AS1530.4-2014, AS4072.1-2005 |
| FRR/FRL   | FR -/120/120<br>PE -/120/60  |
| Reference | PF24145                      |



**Agnitek**<sup>®</sup>  
FIRE RATED TECHNOLOGY

8 Clare St Bayswater  
VIC 3153, AUSTRALIA  
www.agnitek.com.au

#### Disclaimer

Agnitek reserves the right to modify product specifications without prior notice due to its ongoing research, development & certification programme. The information in this document is provided in good faith and is intended for guidance purposes only. Any accompanying drawings are solely for illustrative purposes. Since Agnitek cannot oversee installation methods or ensure site conditions, no warranties, expressed or implied, are intended regarding the products' actual performance. We do not accept liability for any loss, damage, or injury from using this information. Please take a look at the test reports displayed on a relevant AGNI-System webpage for all compliance specifics.

|      |            |
|------|------------|
| Date | 07.03.2025 |
|------|------------|